

<https://raw.githubusercontent.com/RBSC/F4-FMPAC/master/Doc/schematics.png>
<https://i0.wp.com/www.msxinfo.net/wp-content/uploads/2014/03/fmpak.jpg>
https://arduinoplusplus.files.wordpress.com/2019/11/ym2413_schematic.png
<http://www.waveguide.se/?article=46&file=mc3-io-ym2413-sch.png> (<http://www.waveguide.se/?article=the-ym2413-fm-opll>)

TITLE: RC2014-MSX-MUSIC		REV: 1.7
Company: Dino Boards		Sheet: 1/2
Date:	Drawn By: dean.netherton	

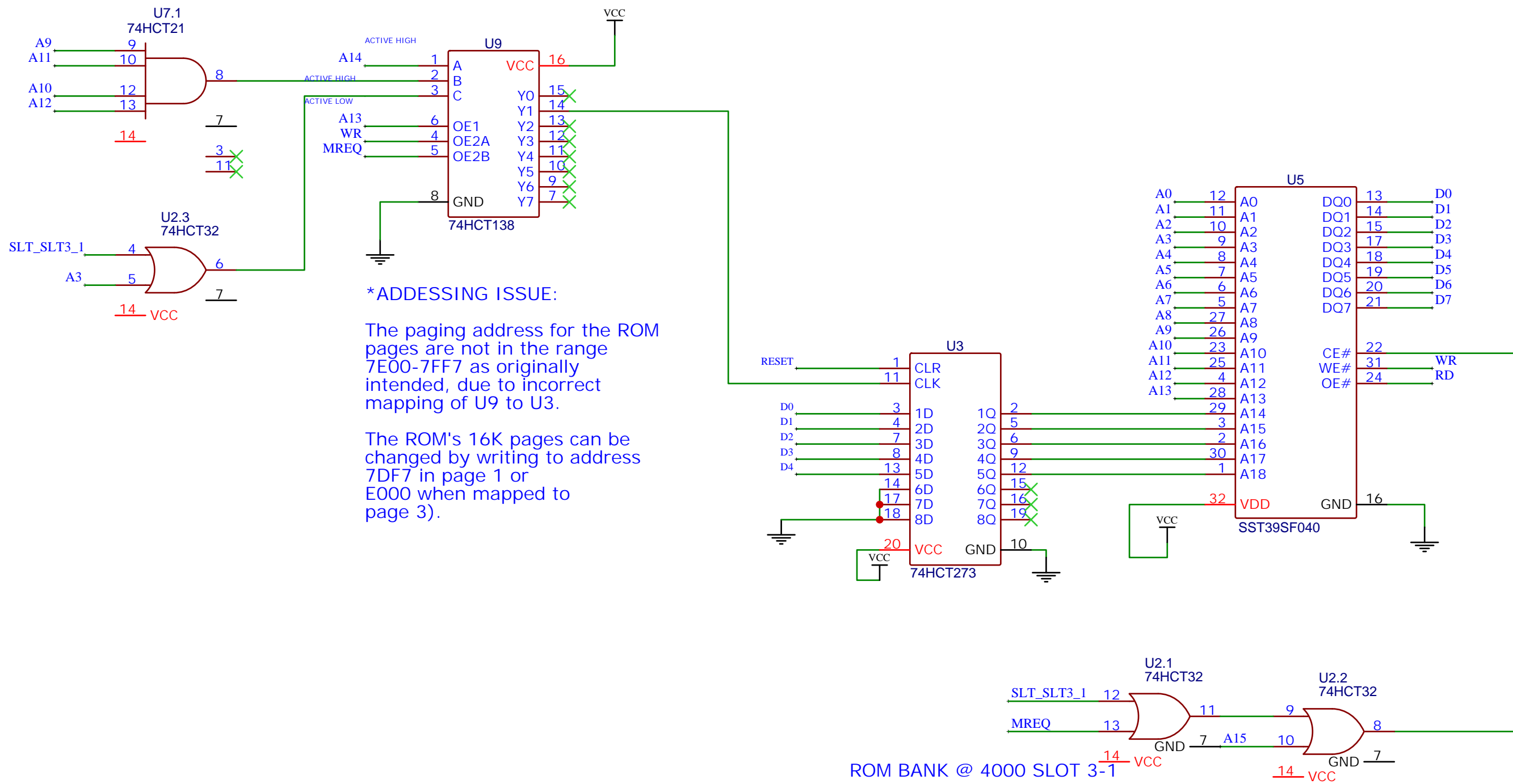



***ADDESSING ISSUE:**

The paging address for the ROM pages are not in the range 7E00-7FF7 as originally intended, due to incorrect mapping of U9 to U3.

The ROM's 16K pages can be changed by writing to address 7DF7 in page 1 or E000 when mapped to page 3).

ROM BANK @ 4000 SLOT 3-1

(Mirrored @ 0000 SLOT 3-1 - though would not typically be mapped)

ROM can not be enabled for pages 2 & 3 (0x8000-0xFFFF), but the paging register U3 can be addressed via page 3, to facilitate flashing of ROM.

TITLE: RC2014-MSX-MUSIC-ROM		REV: 1.7
EasyEDA	Company: DINO BOARDS	Sheet: 2/2
	Date:	Drawn By: dean.netherton